

FOLLO MICRO

Follo series installation instructions

1.

MODEL
TT00101

1、 Notice:

- 1、 All operation must be in de-energized!
- 2、 Ensure the handle is in closed position before assemble the adapter to the track;
- 3、 Put the handle to the point position after assemble the adapter to the track;
- 4、 Keep the power off and ensure the handle is in closed position before taking down adapter;
- 5、 During the installation process, do not hold the lamp body with force, but hold the connector to install;
- 6、 Shall use the track suitable for the lamp, and pay attention to the installation direction of the third-line track, that is, the one side of the light fixture has two copper plates should be fitted on the same side of the third-line track groove with two copper wires

2、 Installation steps:

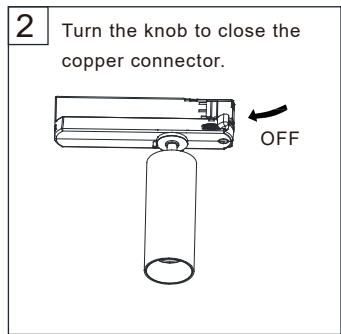
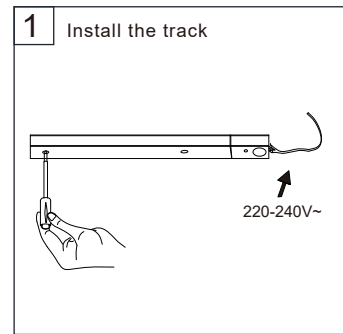

2.

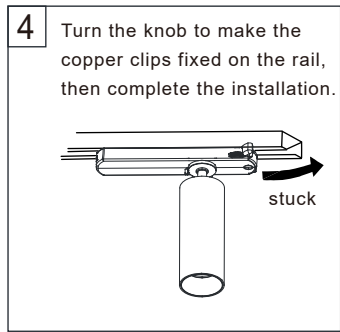
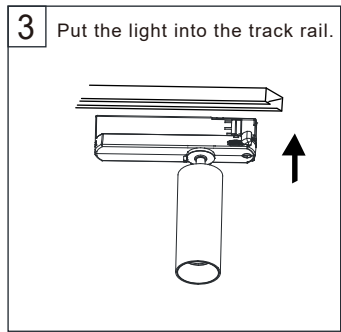
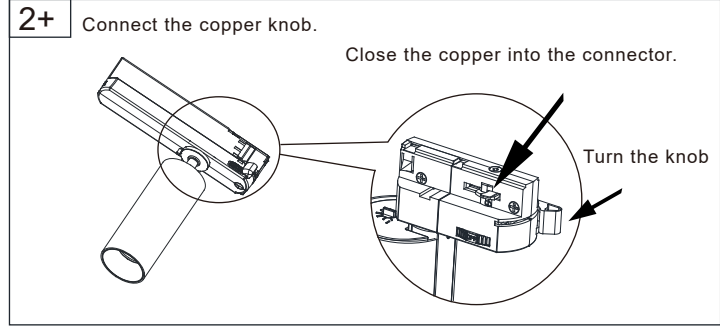

The specific appearance is subject to the real product!

3.

3、 4- wire connection instructions:

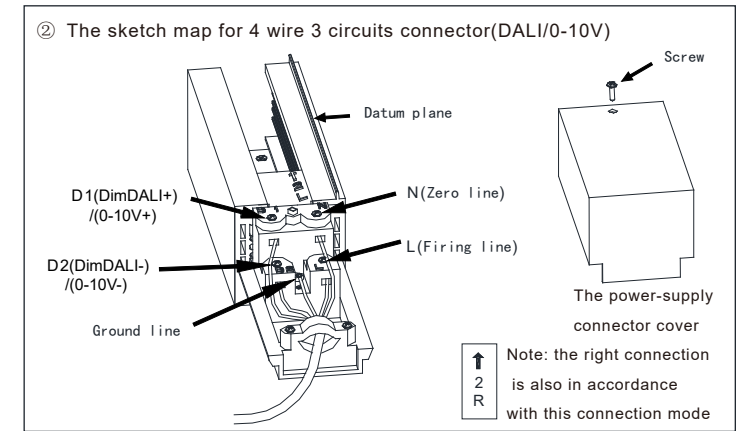
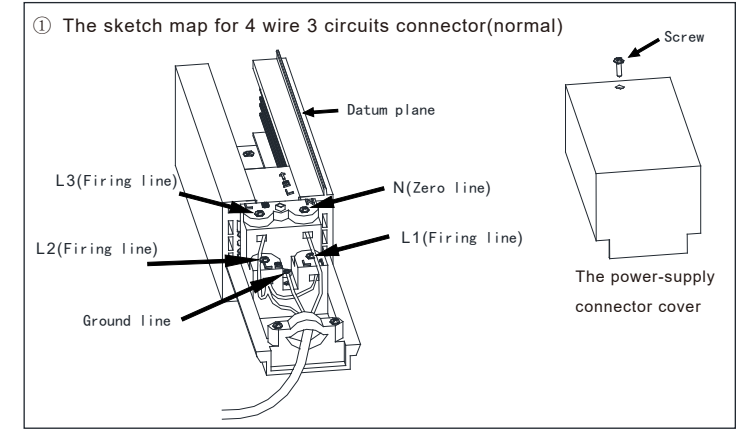

4.

③ The sketch map for the assembling track

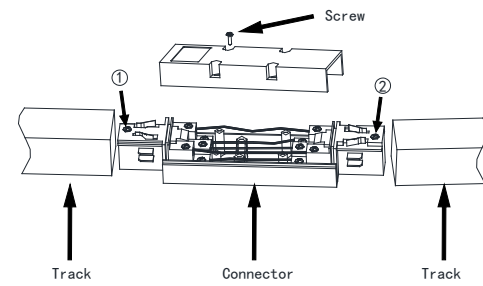

Loose the NO.1 and NO.2 screw counterclockwise before jointing together and entight the NO.1 and NO.2 screw after jointing together.

④ The sketch map for assembling adapter and track

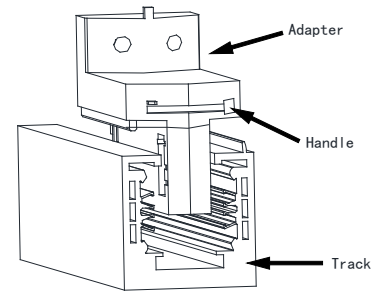

The specific appearance is subject to the real product!

5.

6-wire wiring diagram:

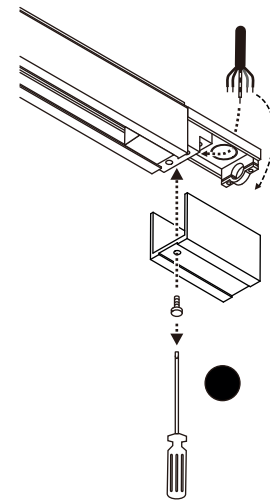
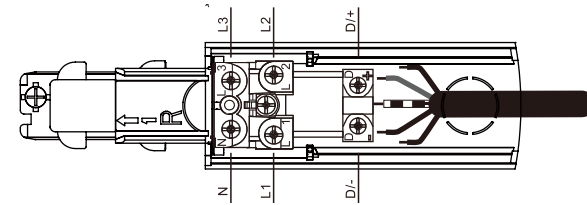

6.

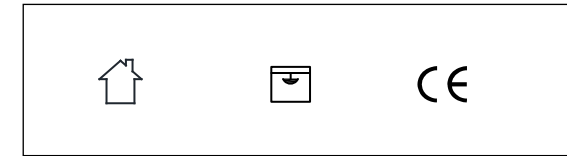

 This product is only suitable for indoor.
It is not allowed to be rinsed with water.

 LED driver is built in, the luminaire is track mounted.

7.

Do not clean LED chip and reflector with hand or towel !



- Use only drivers that comply with IEC or CE safety standards.
- Check if the power supply match with the luminaire.
- Must consider the maximum current value displayed on the label of the luminaire.
- The voltage displayed on the luminaire is not used to select the constant voltage driver, but the voltage covered by the selected constant current driver.
- Take suitable ESD measures to avoid touching bare conductors.
- LED chips can be damaged if be in touch with chemical material or gas. Therefore, it is not allowed to clean the LED housing or luminaire by chemicals.
- The following items are confirmed to have negative impact on the performance of the luminaire, avoid to keep luminaire in the same circumstance with them.
 - Methyl acetate or ethyl acetate (i.e., nail polish remover)
 - Cyanoacrylates (i.e., "Superglue")
 - Glycol ethers (including Radio Shack ® Precision Electronics
 - Cleaner - dipropylene glycol monomethyl ether)
 - Formaldehyde or butadiene (including Ashland PLIOBOND ® adhesive)
 - Dymax 984-LVUF conformal coating
 - Loctite Sumo Glue. Loctite 384 adhesive. Loctite 7387 activator
 - Gorilla Glue. Bleach, Bleach-containing cleaners, sprays
- Remove the insulation material from the luminaire or provide enough space so that the temperature raising will not overpass the limited TC.
- LED chip is very sensitive to switching transients, therefore, LED lamps and appliances must be connected after power cut off, no hotswappable.
- Recommends using the driver indicated on the luminaire manual.
- Must consider the polarity of the product.
- If the external flexible cable or cord of this lamp is damaged, the cord should be replaced by the manufacturer or its service agent or a similarly qualified person
- The light source in this lamp should be replaced by the manufacturer or its service agent or a similarly qualified person

8.